

# Yerf-Dog™

**ATV W2200  
Owner's Manual**

## A.T.V.'S

Yerf-Dog ATV's  
4012 East Broadway Suite 310  
Phoenix, AZ 85040  
1-888-926-6554

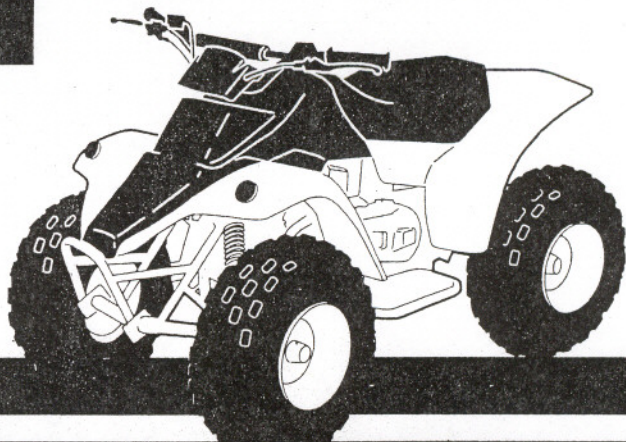

DO NOT RETURN TO RETAILER 1-888-926-6554

**Dear customer,**

Thank you very much for selecting Yerf Dog ATV!

The Yerf Dog Model 23000 are manufactured in accordance with enterprise standard Q/XDZ JC. 62.

Yerf Dog Model 23000 will bring you the greatest pleasure and convenience with their superior performance and elegant style.

Please read this manual carefully before use. It can help you understand the basic structure, functions, operation and maintenance of your ATV so as to let your motorcycle be in the best performance with longer service time, ensuring you more security when riding.

If you have any questions regarding the operation or maintenance of your machine, please consult a Yerf Dog dealer.

May you be pleased with your Yerf Dog ATV!

# CONTENTS

NOTES FOR SAFETY . . . . .	1	Parking . . . . .	13
DESCRIPTION . . . . .	1	Turning . . . . .	14
Parts Location . . . . .	2	MAINTENANCE . . . . .	15
Serial Number . . . . .	3	Maintenance Schedule . . . . .	15
Parts Function . . . . .	4	Spark Plug . . . . .	16
Fuel . . . . .	7	Air Cleaner . . . . .	17
Engine Oil . . . . .	9	Brakes . . . . .	18
Tires . . . . .	10	Drive Chain . . . . .	18
OPERATION . . . . .	11	Throttle Cable . . . . .	19
Inspection . . . . .	11	Battery . . . . .	19
Starting Procedure . . . . .	12	SPECIFICATIONS . . . . .	20
Break-in . . . . .	12	WIRING DIAGRAM . . . . .	21
Riding . . . . .	13		

---

## NOTES FOR SAFETY

---

- ★ This vehicle is designed for junior riders. The designed weight is 68kgs (150 pounds) or less.
- ★ Both the parent and their children must fully understand everything in this manual before riding.
- ★ This vehicle is for OPERATOR - ONLY.
- ★ FOR OFF-ROAD USE ONLY. This vehicle is designed to be operated only on level, off road surfaces, free of obstacles.
- ★ It is illegal to ride this vehicle on public roads or highways. If it is necessary to cross a public road, please get off this vehicle and push it across.
- ★ Don't allow your child to ride without your supervision.
- ★ Do not operate this vehicle while under the influence of alcohol or drugs. This can impair judgement and result in serious injury or even death.
- ★ Maintain a safe distance between your vehicle and other off-road vehicles.
- ★ ALWAYS wear a helmet, face shield, boots, gloves, and protective clothing.
- ★ READ the owner's manual carefully before riding.
- ★ NEVER ride this vehicle unless it has been properly adjusted and maintained.
- ★ WARM UP your body before riding with some exercises.
- ★ LEARN to ride this vehicle properly. Let a good coach teach you.
- ★ ASK your parent or instructor to refuel the fuel tank.
- ★ NEVER run the engine in an enclosed area. The exhaust gas contains poisonous CARBON MONOXIDE.
- ★ DON'T touch any part of the engine or muffler. It is very dangerous for you.

---

## DESCRIPTION

---

### PARTS LOCATION

- (1) Fuel tank
- (2) Front valve
- (3) Front brake lever
- (4) Throttle lever
- (5) Rear brake / parking brake lever
- (6) Engine stop switch

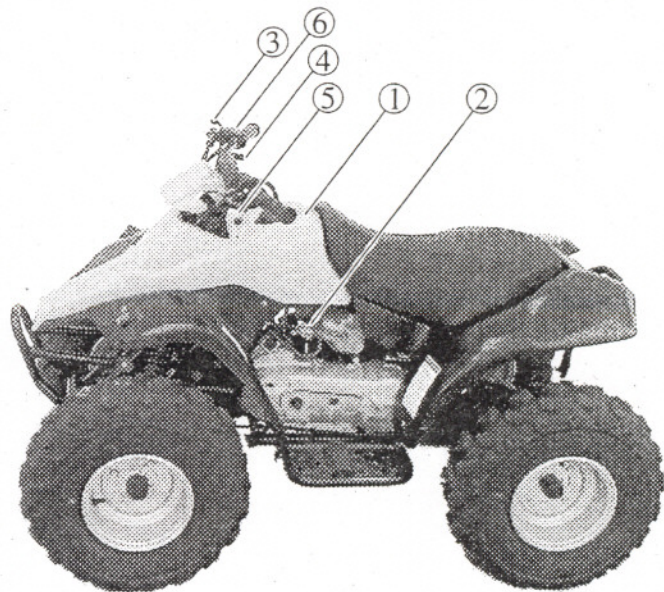

## SERIAL NUMBER

Please record the frame and engine serial numbers for future reference. The frame serial number ① is stamped on the front of the frame.

FRAME NO. \_\_\_\_\_

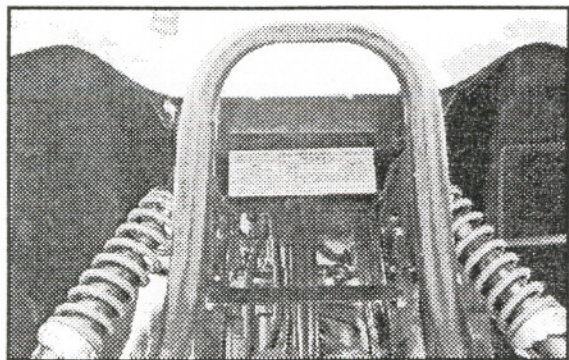

① Frame serial number

The engine serial number ② is stamped on the left side of the crankcase.

ENGINE NO. \_\_\_\_\_



② Engine serial number

## PARTS FUNCTION

### Engine Stop Switch

The engine stop switch is on the left handlebar. When the switch is in the “OFF” position, the engine will not operate. This switch can be used as a safety or emergency switch. When the switch is in the “ON” position, the engine will operate.

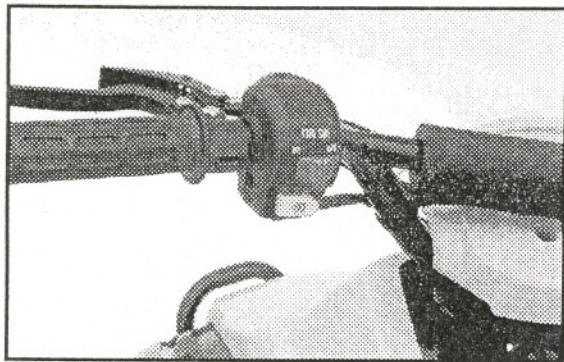

Engine Stop Switch

### Throttle Lever

The throttle lever is beside the right handlebar grip and is activated by the right hand thumb. To accelerate the vehicle, simply press the lever forward to open the throttle. To decelerate, release the lever, spring tension will close the throttle automatically.

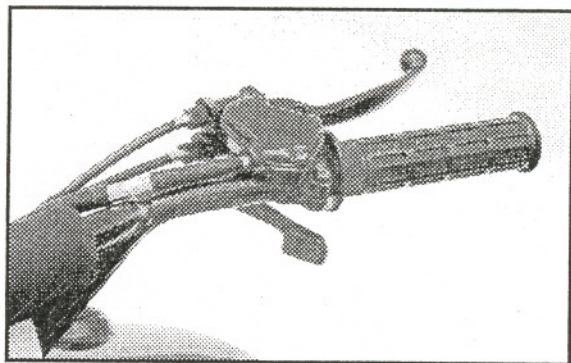

Throttle lever

## Rear Brake

The rear brake is the lever located on the left handlebar. When braking, squeeze this lever. This applies the brake to the rear wheels. This brake also has a locking feature and allows the rear brake to be used as a parking brake. To use the parking brake, pull the left brake lever back and lock it. Make sure the vehicle is completely stopped before using the parking brake. To release the parking brake, squeeze firmly on the brake lever until the lock releases.

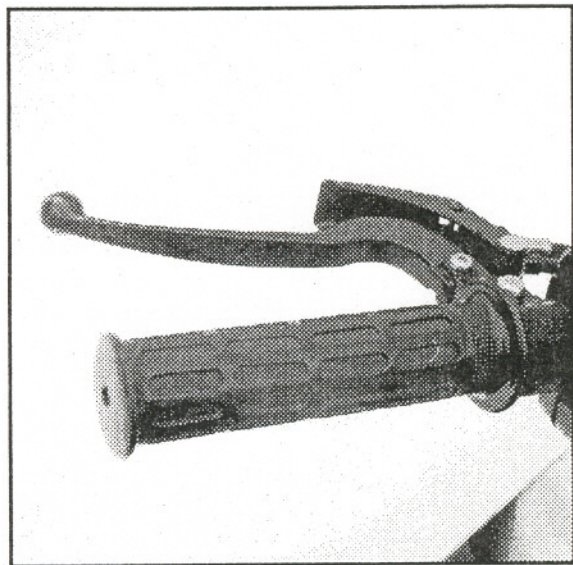



## Safety Switch

This vehicle is equipped with a rider safety system. The safety switch is located on the rear fender. To operate the vehicle, the switch cap must be connected to the safety switch. The switch cap is attached to a rope. The safety switch rope should NEVER be attached to the rider. A parent or supervisor should hold the safety switch from behind the vehicle and pull it to activate the safety switch if necessary.

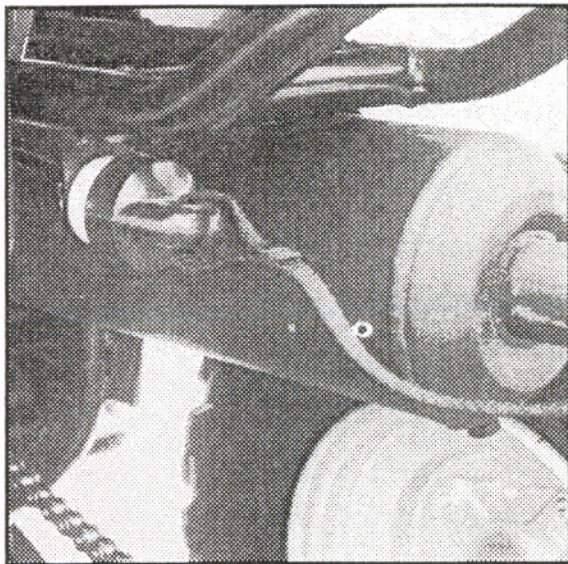

## FUEL

### Fuel Valve

The three way fuel valve is on the left side of the vehicle.

With the fuel valve at **“OFF”**, gasoline cannot flow into the carburetor.

With the fuel valve at **“ON”**, fuel will flow out from the tank.

With the fuel valve at **“RES”**, fuel will flow from the reserve fuel supply to the engine.

At this condition, refill the tank as soon as possible.

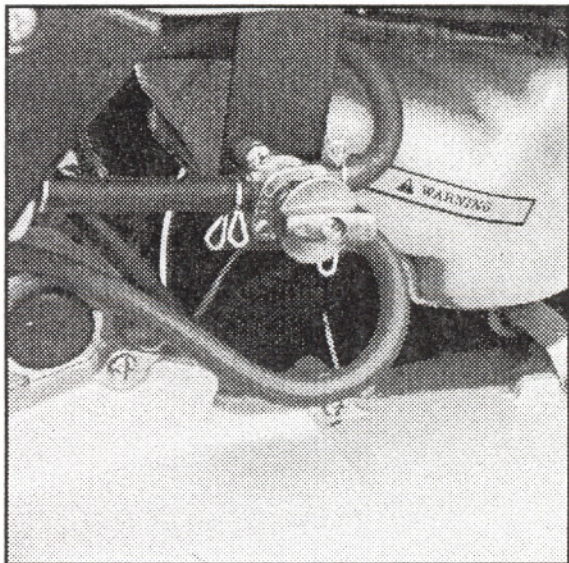

## Fuel Tank

Fuel tank capacity is 4.5 liter including 0.8 liter in the reserve supply.

Automotive gasoline with octane level of 91 or higher may be used.

After refueling, be sure to tighten the tank cap firmly.

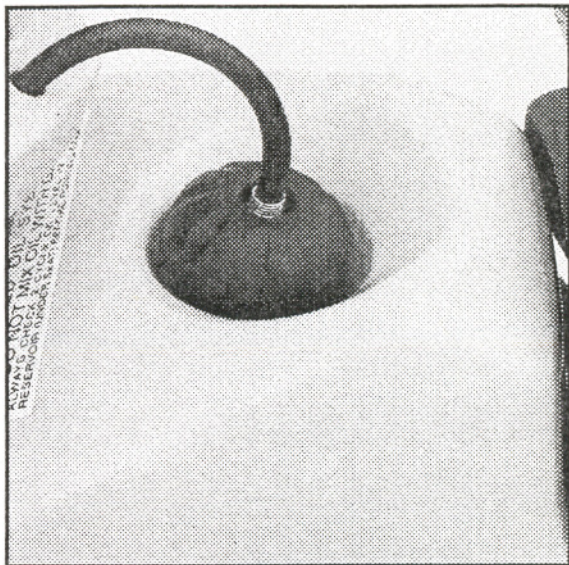

## ENGINE OIL

The oil tank is located under the seat. Look at the oil level before each use. When the oil level gets to the warning level (about 1/2 inch from the bottom of the tank), add oil to the tank.

To add oil, remove the seat assembly and lift off the rear seat. Add oil to the tank and carefully replace the seat assembly.

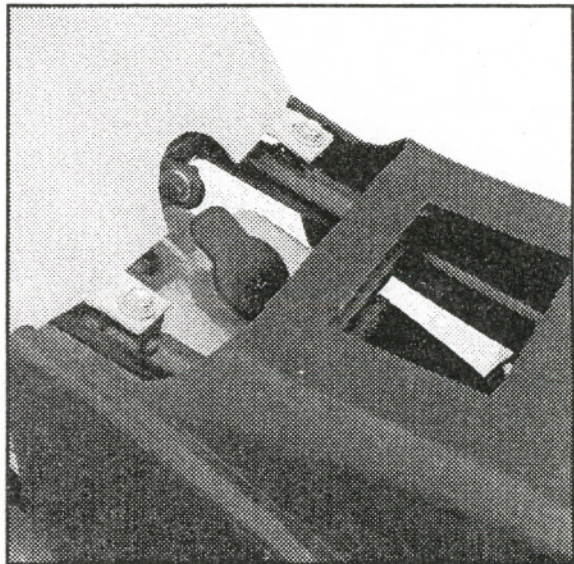

## TIRES

Check tire pressure frequently with the air pressure gauge. Tires should be inflated to the recommended pressure.

- ★ The recommended pressure: 2.2 psi (15 kPa)  
Max. Pressure                      2.6 psi (18 kPa)  
Min. Pressure                        1.8 psi (12 kPa)

- ★ The pressure should be checked when the tires are “cold”, before running the vehicle.



## **INSPECTION**

Inspect your vehicle every day before you run it. It only takes a few minutes but it can be well save your life.

- ★ Check oil level in oil tank.
- ★ Check fuel level in fuel tank.
- ★ Check brake operation.
- ★ Check tires condition and pressure.
- ★ Check drive chain condition and slack.
- ★ Check throttle for smooth opening and closing.
- ★ Check engine stop switch and safety switch for good function.
- ★ Check steering for the wheels can turn properly.
- ★ Check nuts, bolts and other fasteners.

## **STARTING PROCEDURE**

1. Parking the vehicle on a level surface and lock the parking brake.
2. Insert the ignition key into its switch and turn it to the "ON" position.
3. Turn the fuel valve "ON".
4. Move the engine stop switch to "ON".
5. Push the start button on the left handlebar.

## **BREAK-IN**

During the first two weeks of riding, run your new vehicle tenderly. Don't run very fast and don't approach maximum rpm. This break-in process will greatly enhance the long term power and life of the engine.

## **RIDING**

For your initial, select a safe area free of obstacles with a level surface.

Under normal riding conditions, it is not necessary to touch the ground for balance.

1. Start the engine.
2. After the engine has been warmed up, release the parking brake. The vehicle is ready for riding.
3. Increase engine speed by gradually opening the throttle.

## **PARKING**

1. Parking at a level surface.
2. Stop the vehicle, move the engine stop switch OFF.
3. Lock the parking brake at the left handle bar.



## **TURNING**

The rider must learn to move his weight and control the throttle to allow the rear tires to get the turn. When turning, the wheel on the outside of the turn must travel a wider radius and thus a greater distance than the inside wheel. As the rear axle does not permit a differing rate of wheel rotation, it is not enough to merely steer this vehicle into a turn.

To turn, steer in the direction of the turn, leaning your body to the inside of the turn, while supporting your weight on the outer footpeg. Use the throttle to maintain power throughout the turn.

Incorrect turning may cause the front wheels to slide straight ahead. If this should occur, close the throttle and stop. Avoid braking or accelerating until you have regained directional control. To avoid skids while traveling on slippery terrain.

## MAINTENANCE

### MAINTENANCE SCHEDULE

The maintenance intervals in the following table are based upon average riding conditions. Riding in unusually dusty areas, require more frequent servicing.

	INITIAL SERVICE (First week)	REGULAR SERVICE (Every 30 operating days)	EVERY YEAR
FUEL LINE			I
THROTTLE OPERATION	I	I	
AIR CLEANER		C	
SPARK PLUG		I	
CARBURETOR IDLE SPEED	I	I	
DRIVE CHAIN	I,L	I,L	
BRAKE SHOE WEAR			I
BRAKE SYSTEM	I	I	
NUT, BOLT, FASTENER	I	I	
WHEEL	I	I	
STEERING SYSTEM			I
SUSPENSION SYSTEM			I

I: Inspect and Clean, Adjust, Lubricate or Replace, if necessary

C: Clean

L: Lubricate

## SPARK PLUG

Standard spark plug: NGK BPR7HS or BP7HS

1. Disconnect the spark plug cap.
2. Clean up dirt from around the spark plug base.
3. Remove the spark plug.
4. Inspect the plug electrodes for wear. If the electrodes and insulator tip appear unusually fouled or burned, change to a new one.
5. Discard the spark plug if there is apparent wear or if the insulator is cracked or chipped.
6. Install the spark plug, screw it in finger tight and then tighten with the plug wrench another 1/2 turn to compress the washer.

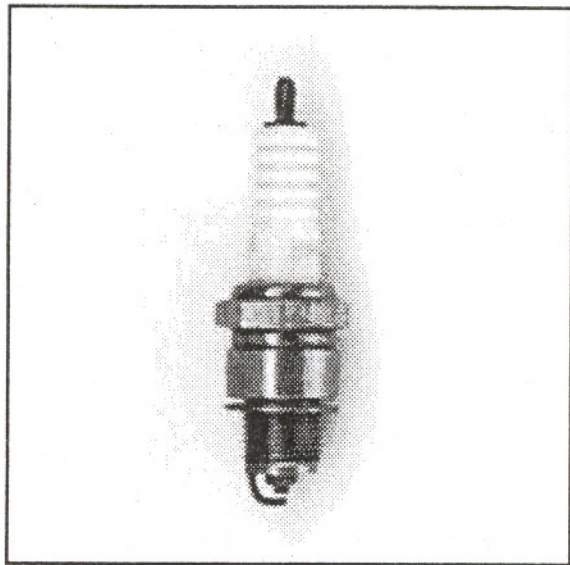

## AIR CLEANER

The air cleaner will accumulate dust and must be cleaned periodically. If riding in very dusty area, the filter must be cleaned more frequently.

To clean the filter

1. Remove the air cleaner cover.
2. Take out the filter from the air cleaner case.
3. Wash the filter element in a non - flammable or high flash - point solvent. Soak the element in clean oil until saturated, then squeeze out the excess oil.
4. Let the filter element dry and reinstall it.

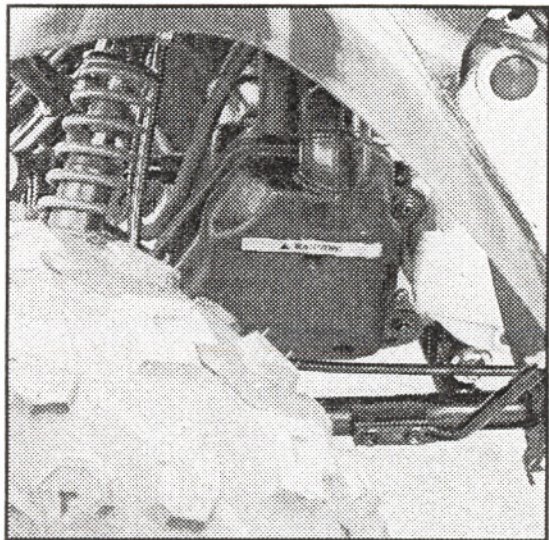

## **BRAKES**

Check the brake cable for kinks or signs of wear that could cause sticking or failure. Lubricate the brake cable with an available cable lubricant to prevent premature wear or corrosion. Make sure the brake arm, spring, rod and fasteners are in good condition.

## **DRIVE CHAIN**

The drive chain will wear with use and requires periodic adjustment. Remove the chain cover, measure the amount of chain slack to check the chain tension. The amount of slack should be 10 - 20 mm.

The chain slack can be adjusted by loosening the lock nuts and move the chain tensioner plate. Don't forget to tighten the lock nuts well. Sometimes, it needs to lubricate the chain. The SAE 80 or 90 gear oil is recommended.

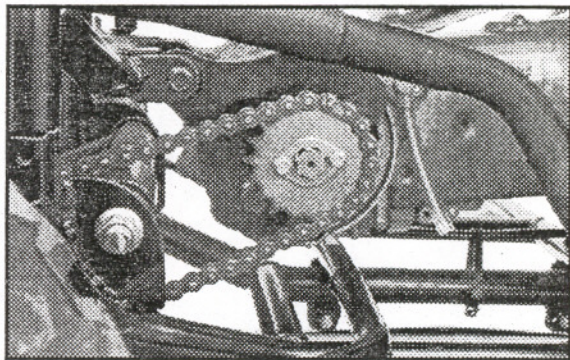

## THROTTLE CABLE

Inspect throttle cable condition and operation. Replace the cable if it has become worn or kinked. Lubricate the cable with lubricant to prevent premature wear or corrosion.

Adjustment can be made with the adjuster beside the throttle lever. Loosen the lock nut and turn the adjuster. The free play should be maintained at 5 - 10 mm.

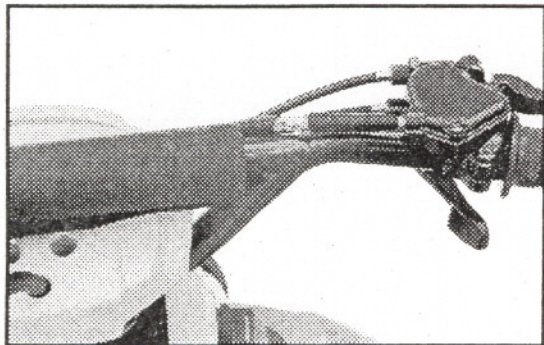

## BATTERY

When reinstalling the battery, be sure to connect the red cable to the positive (+) lead and the black cable to the negative (-) lead. When the battery no longer can hold a charge, replace it. The battery should be replaced every three years as a normal service.

## SPECIFICATIONS

Item		Specifications	
The engine	Model:	XDZ1PE40QMB - 3	
	Type:	Air - cooled 2 - stroke	
	Bore x Stroke:	40.0 x 39.2 mm	
	Displacement:	49.3 c.c	
	Compression ratio:	7.5: 1	
	Oil tank capacity:	1.0 liter	
	Transmission:	Automatic (C. V. T. V - belt)	
Chassis		XDZ50QST	XDZ50QST - A
	Overall Length:	1330 mm	1430 mm
	Overall Width:	830 mm	800 mm
	Overall Height:	830 mm	830 mm
	Wheelbase:	900 mm	900 mm
	Dry Weight:	85 kg	85 kg
	Fuel Tank capacity:	4.5 liter	4.5 liter
Suspension	Front:	Dual Arm	
	Rear:	Swing Arm	
Tire	Front:	16 x 8 - 7	
	Rear:	16 x 8 - 7	

# WIRING DIAGRAM

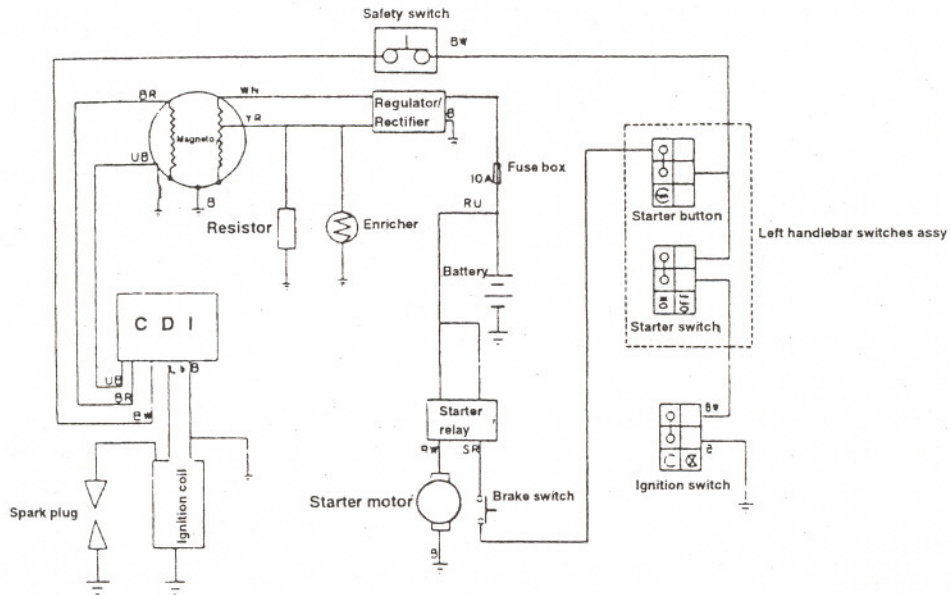

Color	Red	Yellow	White	Black	Brown	Green	Blue	Grey	Orange	Purple	Light blue
Code	R	Y	W	B	N	G	U	S	O	P	Lb



---

## Follow - up

---

Dear customer,

All the materials and diagrams of this manual are in accordance with the newest products at the publishing time. Due to revision and other change, the information described in this manual may be a little different from the actual status. Yerf Dog will reserve the right to revise at any time. The revision will be made without notice.

Any part of the manual should not be allowed to be duplicated, quoted or printed without the permission of Yerf Dog.

**Assembled in the United States**

**Customer Assistance: 1-888-926-6554**